

KBC121340 12V 134Ah



The Kaise cyclic batteries were developed for deep discharges with very heavy non-porous battery plates to withstand major discharging and charging cycles (deep cycle). These batteries use different chemistry combinations for the plates with active paste material and a slightly stronger than normal electrolyte, which allows for a much longer life in deep cycle applications.



Performance Characteristics

Nominal Voltage	12V	
Dimensions	Length (mm / inch)	341 / 13.4
	Width (mm / inch)	173 / 6.81
	Height (mm / inch)	283 / 11.1
	Total Height (mm / inch)	287 / 11.3
Approx Weight	(Kg / lbs) 40 / 88.2	
Design Life	10 years	
Terminal	M8	
Container Material	ABS	
Rated Capacity	131Ah / 13.1A	(10hr, 1.70V / cell, 25°C / 77°F)
	81.3Ah / 81.3A	(1hr, 1.70V / cell, 25°C / 77°F)
	43.8Ah / 263A	(10min, 1.70V / cell, 25°C / 77°F)
Max. Discharge Current	950A (5s)	
Internal Resistance	Approx 3.8mΩ	
Operating Temp. Range	Discharge : -15 ~ 55°C (5 ~ 131°F)	
	Charge : 0 ~ 40°C (32 ~ 104°F)	
	Storage : -15 ~ 40°C (5 ~ 104°F)	
Nominal Operating Temp. Range	25 ± 3°C (77 ± 5°F)	
Cycle Use	Initial Charging Current less than 26.8A	
	Voltage: 2.30VPC ~ 2.35VPC at 25°C (77°F)	
	Temp. Coefficient: -30mV/°C	
Standby Use	Initial Charging Current less than 26.8A	
	Voltage: 2.25VPC ~ 2.30VPC at 25°C (77°F)	
	Temp. Coefficient: -20mV/°C	
Capacity affected by Temperature	40°C (104°F)	103%
	25°C (77°F)	100%
	0°C (32°F)	86%
Self Discharge	Fully charged Kaise Deep Cycle Series batteries may be stored for up to 6 months at 25°C (77°F) and then a freshening charge is required. For higher temperatures the time interval will be shorter.	

Discharge Constant Current (Amperes) at 77°F (25°C)

Volts/cell	10min	15min	30min	1h	3h	5h	10h	20h
1.80V	232	201	119	76.3	31.2	21.7	13.0	6.67
1.75V	247	210	122	78.9	32.1	22.1	13.1	6.70
1.70V	263	220	127	81.3	32.8	22.5	13.1	6.75
1.60V	294	239	135	83.6	34.3	23.3	13.3	6.80

Dimensions and Terminal (Unit: mm (inches))

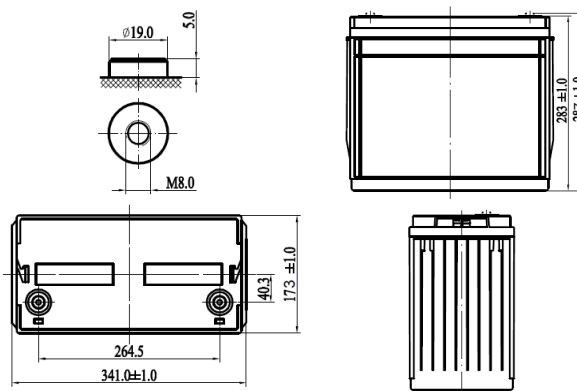

Applications

- Solar power systems
- Electric wheel chairs
- Golf carts
- Maritime equipment
- Power plants
- Railway systems
- Telecommunications systems
- Cable TV systems
- Emergency power systems

Certifications

ISO 9001:2008 ISO 14001:2008



Discharge Current vs. Discharge Voltage

Final discharge voltage V/CELL	1.8	1.75	1.7	1.6
Discharge current (A)	$I \leq 0.1CA$	$0.25CA \geq I > 0.1CA$	$0.55CA \geq I > 0.25CA$	$I > 0.55CA$

Discharge Constant Power (Watts per cell) at 77°F (25°C)

Volts/cell	10min	15min	30min	1h	2h	3h	5h
1.80V	423	369	226	153	86.9	62.5	44.6
1.75V	453	382	234	158	87.8	63.7	45.0
1.70V	478	396	242	163	89.4	64.4	45.3
1.60V	531	423	256	168	92.6	66.0	45.9

(Note) The above characteristics data are average values obtained within three charge/discharge cycles not the minimum values.

Charging Characteristics (standby use)

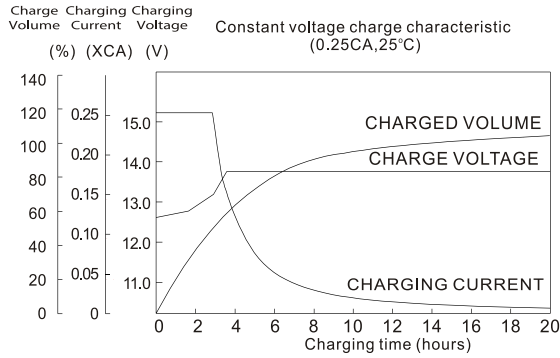

Self Discharge Characteristics

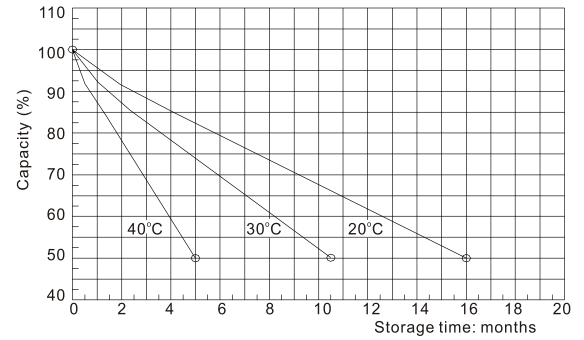

Temperature Effects in Relation to Battery Capacity

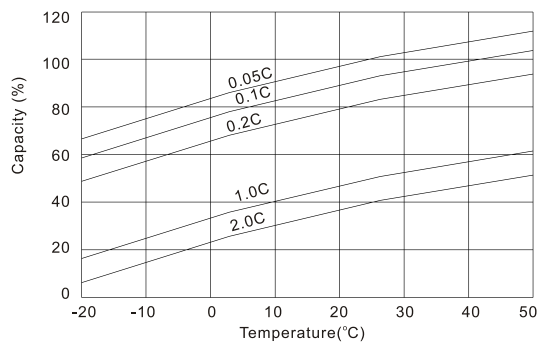

Temperature Effects on Float Life

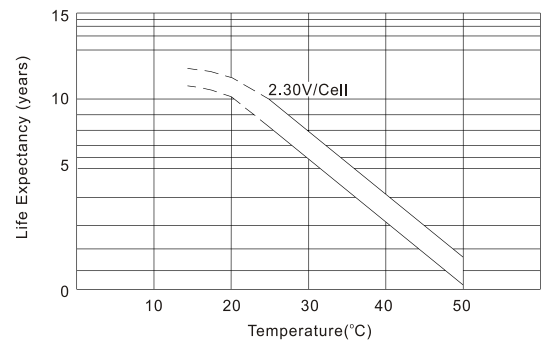

Cycle Life in Relation to Depth of Discharge

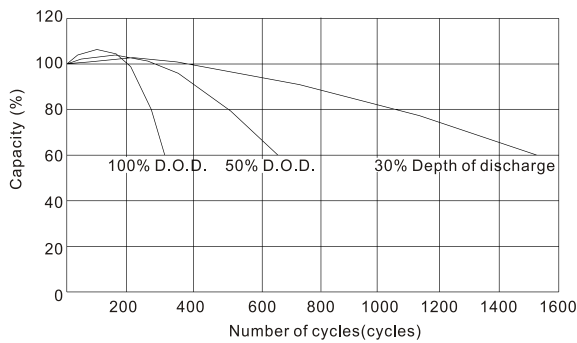

IMPORTANT NOTE: The specifications presented herein are subject to revision without notice.